

A

B

C

D

E

F

Pos	Name	Standard	Material	Leister	Bossard
101	Countersunk screw M4 x 8	ISO 14581	INOX A2	130.943	3061694

Standard components can no longer be ordered as a single unit.  
They are only available on request and restricted to a minimum order quantity.

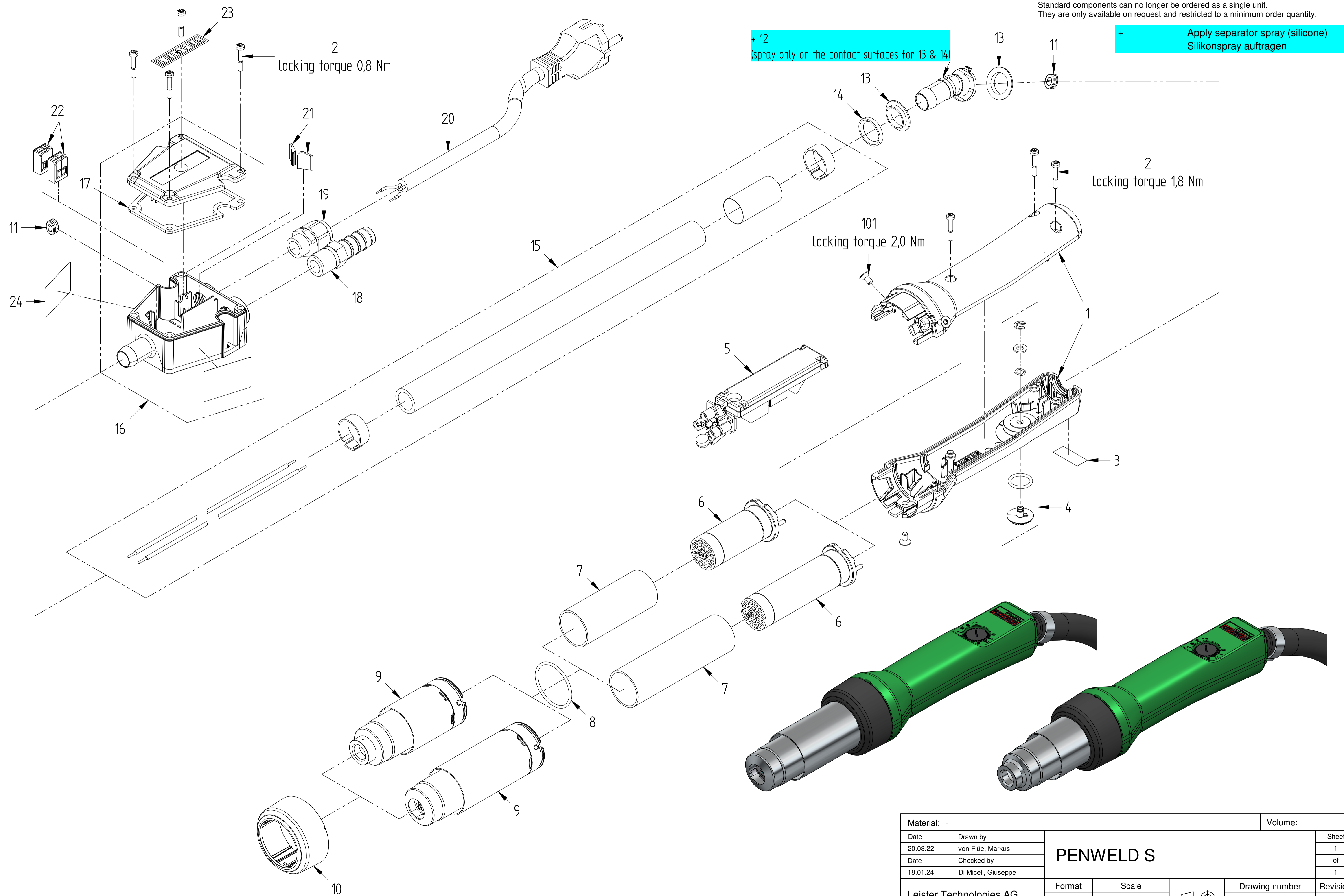

Material: -		Volume:	
Date	Drawn by	PENWELD S	Sheet
20.08.22	von Flüe, Markus		1
Date	Checked by	Format	of
18.01.24	Di Miceli, Giuseppe		A2
Leister Technologies AG Switzerland		Scale	Drawing number
		1:1.75	021.026
		Revision	C

Model: 020927-001asm